

**QwikCheck™ *Gold***  
**Sperm Quality Analyzer**  
**USER GUIDE**

**V e r s i o n 1 . 0 0**

**F e b r u a r y 2 0 2 2**

**Table of Contents**

<b>SECTION 1: System Overview</b>	
Front Panel	4
Key Pad Navigation	4
Measurement Capillary	4
Semen Parameters	5
Dynamic Range	5
<b>SECTION 2: Technology</b>	
Concentration Measurement	6
Motility Measurement	6
<b>SECTION 3: Getting Started / Set-Up</b>	
Power-On	7
Auto-Calibration and Self-Test	7
Set-Up System Defaults: Time, Date, Printing, WHO Morphology	7
Set-Up Controls	8 and 13
<b>SECTION 4: Testing Semen Samples</b>	
Patient Information	9
Sample Data	9
Sample Testing: Fresh – Normal / Diluted / Low Volume Samples	10-11
Low Quality Test Results – Frozen / Washed	12
Printing	12
<b>SECTION 5: Controls and QC</b>	
Control Set-Up and Testing	13
Set-Up: Assayed Control	13
Set-Up: Non Assayed Control	13
Running CONTROLS	14
Electronic Self-Test and Auto-Calibration	15
<b>SECTION 6: Test Credit Loading</b>	
Add I-button Tests or Test Credit (TC) Codes	16
<b>SECTION 7: Service Menu</b>	
Service Data	17
Set-up	17
Service Personnel	17
Printing System Default Settings	17
<b>SECTION 8: Error Messages and Warning Messages</b>	
Stabilization Failed	18
Self-Test Failed	18
Electronic Noise	19
Concentration Out of Range	19
APPENDIX 1: Filling the Testing Capillary with a Normal Volume Sample	20
APPENDIX 2: Filling the Testing Capillary with a Low Volume Sample	21
APPENDIX 3: Cleaning the Capillary Compartment	22
APPENDIX 4: Reference Values of Semen Variables	23
APPENDIX 5: Product Performance Data	24

APPENDIX 6: Service Report	27
APPENDIX 7: QwikCheck Report Printouts	29
APPENDIX 8: Warranty	30
APPENDIX 9: Regulatory Information	31

## SECTION 1: System Overview

The QwikCheck™ *Gold* is a high performance, menu driven analytical medical device for assessing human semen. The combination of technology in electro-optics and computer algorithms results in a precise and accurate 75-second semen analysis. The system is self-testing and self-calibrating and runs latex beads or stabilized sperm quality controls.



### QwikCheck™ *Gold* Keypad

#### Keypad Navigation

- Use **NUMERIC** keys to enter data; **ARROW** keys to move to the next field.
- Press **ENTER** to select menu options, confirm data entries and to move to the next screen or field.
- Use the **ESC** button to return to the previous screen or field.

#### Testing Capillary

### QwikCheck™ *Gold* Testing Capillary

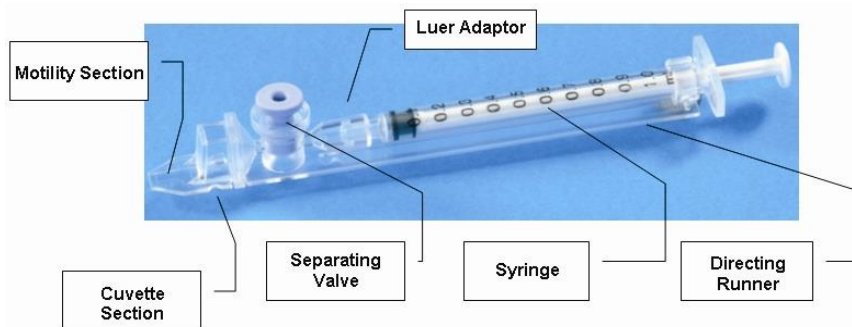

- Disposable, designed to collect and test samples in a biologically safe manner.
- Motility is measured in the 0.3 mm (thin) "Capillary Section." This section requires 20 micro liters of semen.
- Concentration is measured in the 10 mm (tall) "Cuvette Section." This section requires 450 microliters of semen.

**Automated Test Results**

**Semen Parameters Reported by the QwikCheck™ *Gold***

<b>Semen Parameters with QwikCheck GOLD Abbreviation in Brackets</b>			
Sperm Concentration (SPERM CONC.)	M/ml	Motile Sperm Concentration (MSC)	M/ml
Motility (MOTILITY <a + b + c>)	%	Progressively Motile Sperm Conc (a) (PMSC <a>)	M/ml
Rapid Progressive Motility (a) (RAPID PROG. MOTILITY <a>)	%	Progressively Motile Sperm Conc (b) (PMSC <b>)	M/ml
Slow Progressive Motility (b) (SLOW PROG. MOTILITY <b>)	%	Functional Sperm Concentration. Prog. Motile Sperm w/normal morphology (FSC)	M/ml
Non Progressive Motility © (NON PROG. MOTILITY <c>)	%	Total Number Sperm / Ejaculate (SPERM #)	M
Immotility (d) (IMMOTILTY <d>)	%	Total Progressive Sperm / Ejaculate (PROG. SPERM)	M
Velocity (VELOCITY)	mic. /sec.	Total Motile Sperm / Ejaculate (MOT. SPERM)	M
Morphology: % Normal Forms (MORPH. NORM. FORMS,WHO 3 <sup>rd</sup> / 4 <sup>th</sup> )	%	Total Functional Sperm/Ejaculate (FUNC Sperm)	M

**Dynamic Range**

**Table of the Dynamic Range of the QwikCheck™ *Gold***

<b>DYNAMIC RANGE OF THE SYSTEM Gold</b>			
<b>SAMPLE</b>	<b>SPERM CONC in M/ml</b>	<b>MSC in M/ml</b>	<b>Motility %</b>
FRESH	2-400 or < 2 M/ml	0.2-400 or <0.2 M/ml	0-100%
WASHED	2-200 or < 2 M/ml	0.2-200 or <0.2 M/ml	0-100%
FROZEN	Not reported	0.2-200 or <0.2 M/ml	Not reported

**Technology**

**SECTION 2: Technology**

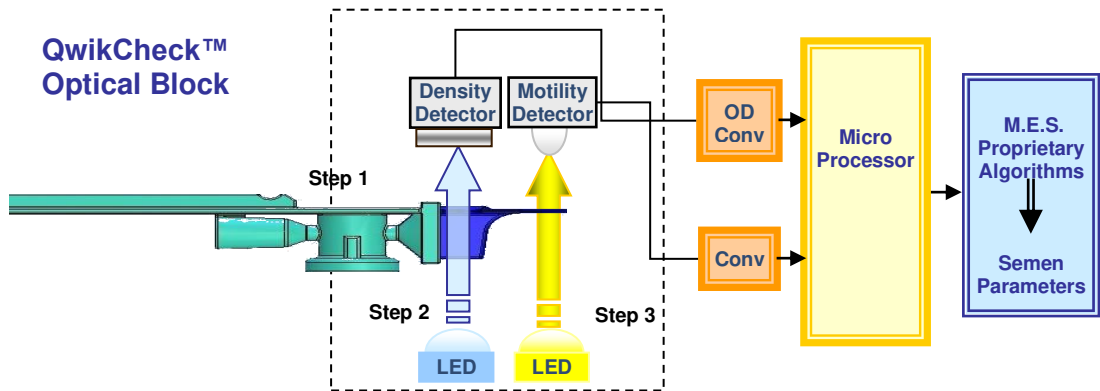

**Step 1: The capillary is inserted into the measurement compartment.**

**Step 2: Concentration:**

- Millions of sperm cells are analyzed: A very specific wavelength of light is absorbed by the sperm cells in the concentration chamber of the testing capillary.
- An detector measures the amount of light absorbed by the cells and converts it to optical density (OD).
- The "OD" reading is translated into sperm concentration by a microprocessor based on proprietary algorithms.

**Step 3: Motility:**

- Tens of thousands of sperm cells are analyzed in the thin section of the testing capillary as they move through a light beam in the system, causing light disturbances.
- These light disturbances are converted into electronic signals with "peaks and valleys."
- The electronic signal peaks are analyzed by microprocessor software based on a proprietary MES algorithm and translated into motility parameters.

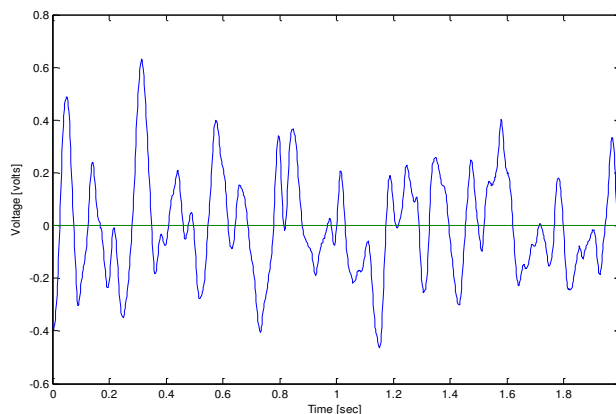

**Electronic Signal of Motile Sperm**

### SECTION 3: Getting Started / Set-Up

#### Power-On

- Plug the system into a grounded electrical source.
- Turn the system on by pressing the main switch located on the rear panel. The **Power** indicator will illuminate and the following screen will be displayed.

QwikCheck GOLD  
SPERM QUALITY ANALYZER  
VERSION 1.0  
  
PRESS ON/OFF KEY  
TO ACTIVATE THE UNIT

#### Auto-Calibration and Self-Test

QwikCheck GOLD  
SPERM QUALITY ANALYZER  
  
PLEASE WAIT  
SYSTEM STABILIZATION AND  
AUTOCALIBRATION

**NOTE:**

Do not use any of the keyboard functions during stabilization.

- Press **ON/OFF** key on the keypad and auto-calibration will begin.
- This process takes 5-7 minutes.
- When the system stabilization and auto-calibration processes are complete, a series of tests will be run.
- Do not insert a capillary into the device or use any of the keyboard functions until instructed to do so by the system.
- The MAIN menu will appear when the self-test process is complete. The system is now ready for use.

**MAIN MENU**  
  
TEST NEW PATIENT  
RUN CONTROLS  
ADD I-BUTTON TESTS  
SERVICE

#### Set-up System Defaults

- Before running a test for the first time, set up the system defaults by going to: **MAIN MENU > SERVICE > SET-UP**

SERVICE MENU  
  
SERVICE DATA  
**SET UP**  
SERVICE PERSONNEL  
PRINT SELF-TEST DATA & SETTINGS

- Select either SYSTEM DEFAULTS or CONTROLS when the screen below appears:

```

SERVICE: SET-UP
SELECT:
1. SYSTEM DEFAULTS
2. CONTROLS
SELECT AND PRESS ENTER
    
```

- **SYSTEM DEFAULTS:** Select the desired formats, Morphology and label printing preference when the screen below is displayed. Press ENTER to accept.

```

SYSTEM DEFAULT SETTINGS
DATE FORMAT: MM/DD/YY / DD/MM/YY
DATE/TIME SETTING: 01/04/05 08:15:45
MORPH SETTING: WHO 3RD (WHO 4TH)
AUTO PRINTING: YES/NO
# LABELS TO PRINT: 1 / 2
    
```

- **CONTROLS:** Follow the screen prompts and enter the appropriate information from the control (Latex beads or Stabilized Sperm) product labeling.

```

SERVICE: SET-UP CONTROLS
SELECT: LATEX BEADS/STABILIZED
SPERM
SELECT: LEVEL 1 / LEVEL 2 / NEGATIVE
PRESS ENTER TO CONTINUE
ESC TO RETURN TO SERVICE MENU
    
```

```

SET-UP: LATEX BEADS
LEVEL 1
LOT #: 0013122009
EXP DATE: 12/03/2010
TARGET VALUE: 46 +/- 6.4
PRESS ENTER
    
```

**NOTE:**

The QwikCheck GOLD is loaded with a minimal number of I-Button tests in memory. However, the user must load tests right away to insure that testing will not be interrupted. Please refer to the I-Button loading section of this manual for instructions!

- Select the type of controls to be run (Latex Beads/Stabilized Sperm)
- Select the LEVEL (1, 2, or NEGATIVE)
- Enter the LOT #/ EXPIRATION DATE and TARGET VALUE from the product labeling.

The **QwikCheck™ Gold** is now ready to test samples and controls!



**Testing Samples**

**Patient Information**

**PLEASE NOTE:**  
The QwikCheck is calibrated to run semen specimens at room temperature. It is not necessary nor will the user get accurate motility results if the sample is heated to 37°C.

**Sample Information**

**PLEASE NOTE:**  
Refer to the appendix section of this user guide for information on how to measure semen WBC's and pH and how to handle viscous samples.

**SECTION 4: Test New Patient:** FRESH, WASHED and FROZEN samples are all run following similar screen instructions. Once the sample type is selected, the menu will direct how to run the sample and what volume is required. If the sample is low quality, the system will perform an additional 2 minute test.

- From the **MAIN MENU** select **TEST NEW PATIENT** and the **ENTER PATIENT / SAMPLE DATA** screen is displayed.

ENTER PATIENT / SAMPLE DATA	
PATIENT ID:	5788114
BIRTH DATE:	01/01/85
ABSTINENCE:	4 DAYS
SAMPLE / ACCESSION #	58888
COLLECTED: DD/MM/YY	HH:MM
RECEIVED: DD/MM/YY	HH:MM

- Enter the requested sample/patient information using the keypad:
  - PATIENT ID** – patient identifying #(Maximum 20 numbers can be entered).
  - BIRTH DATE** – Birth date of the patient.
  - ABSTINENCE** - Number of days since the patient's last ejaculation.
  - SAMPLE/ACCESSION #** - Up to 20 numbers identifying the sample
  - COLLECTED** – Date and time the sample was collected.
  - RECEIVED** – Date and time the sample was received.

Press **ENTER** to view the next screen:

ENTER SAMPLE DATA	
<b>SELECT</b>	FRESH / WASHED / FROZEN
VOLUME	2.5 ml
WBC CONC.	<b>SELECT</b> <= 1 M/ml / OR > 1 M/ml
PH	7.0

**Sample Data**

- Select: **SAMPLE TYPE** based on the following options:
  - FRESH** – Sample not enriched, diluted or treated and is within 1 hour of collection. Exception: Low volume samples diluted 1:1 with QwikCheck dilution media can be used according to User Guide instructions.
  - WASHED** – Sample enriched or prepared for artificial insemination using a commercial media to replace seminal plasma. Frozen samples containing egg yolk buffer are excluded.
  - FROZEN** – Samples that have been frozen. Only motility parameters will be reported (MSC, PMSC, SMI and VELOCITY).
- Enter the remaining sample information:
  - VOLUME** – Volume of the whole ejaculate in milliliters
  - WBC CONC.** – select <= 1 M/ml (normal) or > 1 M/ml (abnormal) leukocytes (required entry). (QwikCheck Test Strips recommended).
  - PH** – pH of the semen sample (QwikCheck Test Strips recommended).

**Normal Volume Samples**

**Sample Volume**

IS SAMPLE VOLUME SUFFICIENT FOR COMPLETE TESTING  $\geq$  .5 ml?  
YES/NO

- After entering the patient and sample data, the screen above will be displayed.
  - **SELECT: YES** for **NORMAL VOLUME** samples  $\geq$ 0.5 ml.
  - **SELECT: NO** for **LOW VOLUME** samples  $<$  0.5 ml.

If **YES:** The sample is  $\geq$ 0.5 ml the screen below provides instructions for PREPARING a testing capillary. Do not touch the system at this time as it is calibrating for the testing cycle.

NORMAL VOLUME SPECIMEN  
FILL, CLEAN & WIPE CAPILLARY  
AUTOCALIBRATION-DO NOT TOUCH UNIT

- Fill the testing capillary according to the instructions in the Appendix section of this user guide: "Filling the SQA Capillary with a Normal Volume Sample".
- Insert the testing capillary into the measurement chamber of the QwikCheck GOLD when instructed by the screen below:

NORMAL VOLUME SPECIMEN  
FILL, CLEAN & WIPE CAPILLARY  
INSERT IN CHAMBER

**TESTING**  
DO NOT MOVE CAPILLARY OR OPERATE DEVICE DURING TESTING

**PLEASE NOTE:**  
The QwikCheck will begin testing when a capillary is placed into the testing chamber.

- Testing will begin automatically – do not touch the system or capillary during testing.
- Test results will be displayed when finished:

TEST RESULTS	
SPERM CONC.	32.6 M/ml
MOTILITY <a+b+c>	28.0 %
RAPID PROG. MOTILITY <a>	5.2 %
SLOW PROG. MOTILITY <b>	14.1 %
NON PROG. MOTILITY <c>	8.7 %
IMMOTILITY <d>	72.0 %
MORPH.NORM.FORMS, WHO 3 <sup>rd</sup>	20.6 %

TEST RESULTS			
FSC	9.1 M/ml	MSC	9.1 M/ml
PMSC<a>	1.7 M/ml	VELOCITY	20mic/sec
PMSC<b>	3.5 M/ml	SMI	72
TOTALS PER EJACULATE			
# SPERM	65.2M	MOT. SPERM	18.2M
PROG.SPERM	10.4M	FUNC SPERM	12.1M

**Low Volume Samples**

**Diluted Samples**

**Recommendation for sample dilution media:**

Use **QwikCheck™ Dilution Media** for best results and if the sample is viscous, FIRST treat with **QwikCheck-Liquefaction kit**, then dilute.

**20µl Low Volume Samples**

If the sample is < 0.5 ml two options are available: DILUTE the sample 1:1 (QwikCheck Dilution media) to obtain a full report or run a LOW VOLUME sample (reports motility parameters only).

To run a **LOW VOLUME DILUTED** sample, select option "1" when the screen below is displayed:

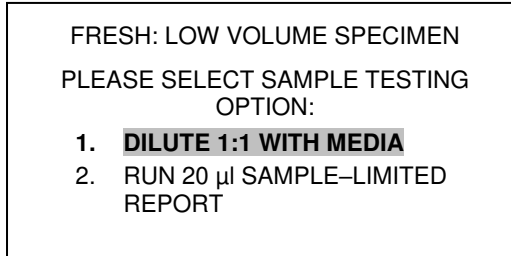

- Dilute the sample 1:1 with QwikCheck dilution media (see appendix section).
- Follow the instructions in the appendix section of this User Guide: Filling the Testing Capillary with a Normal Volume Sample.
- The system will report accurate results only if the sample has been diluted 1:1 precisely and the sample is adequate to fill the testing capillary after dilution.

To run a **LOW VOLUME** sample, select option "2" from the screen displayed below:

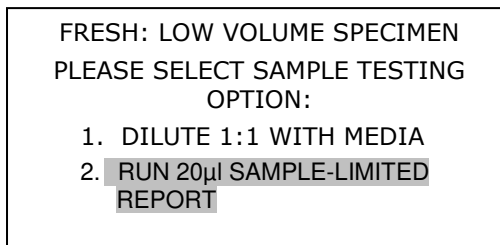

- Aspirate only 20 µl of sample into the motility section of the capillary following the instructions in the Appendix section of this User Guide: "Filling the SQA Capillary with a Low Volume Samples".

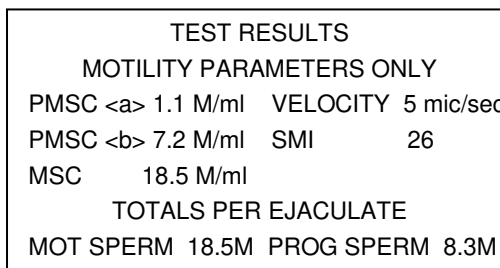
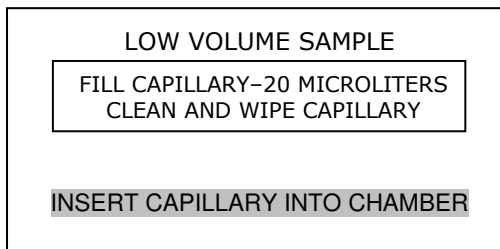

**Low Quality Test Results**

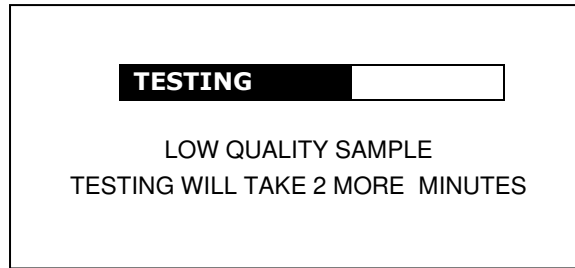

When a sample is LOW QUALITY, test results may be reported as < or > when parameters fall below the dynamic range of the system. Only the following parameters will be reported: Sperm Concentration, Motility, SMI and Motile Sperm Concentration due to the limited number of cells, very low motility and/or poor morphology.

- Examples of test results reported in this manner are seen in the screens below:

TEST RESULTS	
SPERM CONC.	2.7 M/ml
MOTILITY <a+b+c>	< 5 %
RAPID PROG. MOTILITY <a>	%
SLOW PROG. MOTILITY <b>	%
NONPROG. MOTILITY <c>	%
IMMOTILITY <d>	%
MORPH. NORM. FORMS, WHO 3 <sup>rd</sup>	%

TEST RESULTS			
FSC	< 0.2 M/ml	MSC	<0.2 M/ml
PMSC <a>	M/ml	VELOCITY	mic/sec
PMSC <b>	M/ml	SMI	0
TOTALS PER		EJACULATE	
SPERM #	N.A.	MOT. SPERM	N.A.
PROG.SPERM	N.A.	FUNC SPERM	N.A.

**FROZEN, WASHED SAMPLE TESTING**

Run FROZEN and WASHED samples in the same manner by selecting SAMPLE TYPE: FROZEN (or WASHED) from the MAIN MENU > TEST NEW PATIENT > ENTER SAMPLE DATA screen. Follow the on-screen instructions.

- FROZEN samples require only 20 microliters of sample and motility parameters only are reported
- WASHED sample can be run with a large or small volume sample (motility parameters only will be report if using 20 microliters)

**Printing**

- If the QwikCheck was set to automatically print test results on the label maker they will now print.
- If the default was not set, press the PRINT button on the keypad.

**Control  
Set-Up and  
Testing**

**SECTION 5: Controls**

From the MAIN MENU select: RUN CONTROLS in order to run external quality control samples (CONTROLS). Commercially available stabilized sperm can be run as non-assayed controls. QwikCheck™ beads produced by Medical Electronic Systems are assayed for the QwikCheck GOLD. It is recommended that controls be run daily or based upon laboratory protocols.

**Set-Up**

**Set-Up: Assayed Control: QwikCheck™ Beads**

For each new box of controls, system defaults need to be set-up/updated. To do this:

**Please note:**

When a new control lot is used, the control default settings must be changed prior to initiating a test.

- Go to: MAIN MENU > SERVICE > SET-UP > CONTROLS to view the screen below:

```

SERVICE: SET-UP CONTROLS

SELECT: LATEX BEADS / STABILIZED SPERM
SELECT: LEVEL 1/LEVEL 2/NEGATIVE

PRESS ENTER TO CONTINUE
ESC TO RETURN TO SET-UP MENU
    
```

**Please note:**

For the QwikCheck GOLD to test CONTROLS accurately, the CONTROL defaults must be set-up. If some control information is not available, enter the current date in the EXP Date field and zeros in all other fields.

- Select the type of control (LATEX BEADS or STABILIZED SPERM)
- Select the level of the control (LEVEL 1, LEVEL 2 or NEGATIVE)
- PRESS: ENTER and the screen below will be displayed:

```

SET-UP: LATEX BEADS LEVEL #1
LOT #: 112233445566778899
EXP DATE: 04/09 MM/YY
TARGET VALUE: 45 +/- 6.3

PRESS ENTER
    
```

- From the box/product labeling enter:
  - **LOT#:** number identifying the control media lot.
  - **EXP. DATE:** control expiration date (MM = month, YY = year).
  - **TARGET VALUE and +/- Range:** Manufacturer's labeled "Target Value and +/- Range" for the level of the control being set-up.
- PRESS ENTER to save the set-up information.
- Continue to set-up each of the other levels of controls.

To run a non-assayed control, the Target Value and +/- range must be established by the laboratory. Once this is determined, set-up the defaults and test the control in the same way as QwikCheck Beads assayed control.

**Running Controls on the QwikCheck GOLD**

**Please note:**

For the QwikCheck GOLD to test CONTROLS accurately, the CONTROL defaults must be set-up. Please refer to the section above to set-up the controls.

**Please note:**

Insert the testing capillary with the control media ONLY when prompted by the screen.

**CONTROL Testing**

- To run controls go to: **MAIN MENU > RUN CONTROLS** and press ENTER

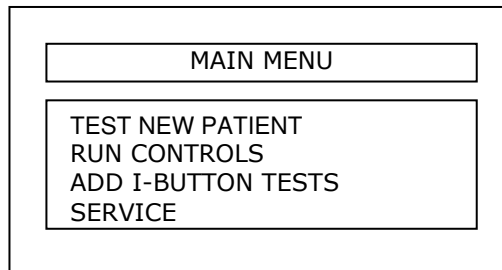

- When the screen below is displayed: Select the **CONTROL LEVEL:** #1, #2 or NEGATIVE (LEVEL #3) that is being tested.
- Press **ENTER** to continue.

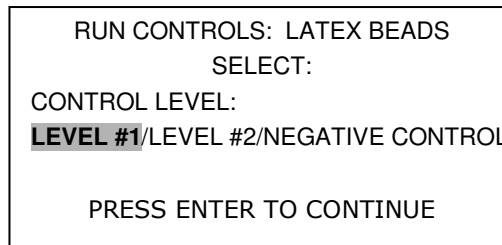

- Fill the testing capillary with the Control media as if you are running a normal volume semen sample.
- After a screen that asks you to PLEASE WAIT while the system auto-calibrates, the screen below will be displayed:

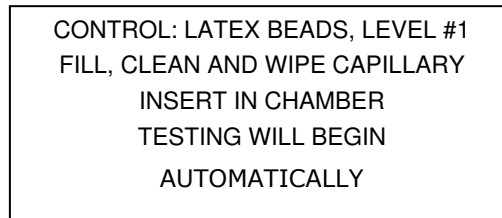

- Testing will begin automatically.
- Control test results will be displayed on the QwikCheck GOLD screen.
- LOW, HIGH or NORM. will be displayed based on the testing outcome vs. target value and +/- range.
- Test results can be printed by pressing the PRINT button on the keypad.

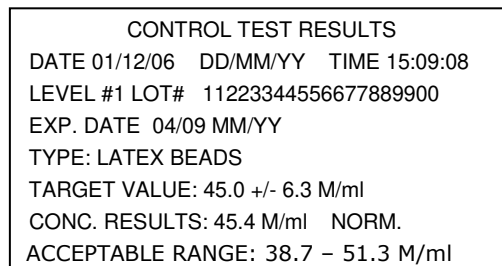

## Electronic Self-Test and Auto Calibration

**The QwikCheck automatically runs a series of tests to check calibration settings and the internal operating system. Tests are run when the system is turned on and prior to testing a sample.**

### Start-up:

- **Stabilization and auto calibration:** Checks system stability and reference ranges. The system sensors are analyzed for several minutes to insure that the values are within a very narrow acceptable range. Once the system is stable for 30 seconds it will pass stabilization and auto calibration. The system will fail if it is not stable for at least 30 seconds and a warning message will be displayed.
- **System noise:** Measures the electronic noise level of the system to insure effective measurement of electronic signals.
- **Self-test:** The system produces electronic signals that simulate motility and concentration measurements in order to check the performance of the system and verify that the calibration settings are consistent with the factory specifications. The QwikCheck will report failures (see section on error and warning messages) and "freeze" the system if the system is not within the established self-test ranges.

### Prior to testing a sample:

- **Auto calibration verification:** Reference values are read again. The electronic parameters of the concentration and motility channels are measured (without a testing capillary).
- **System noise:** Measures the electronic noise level of the system to insure effective measurement of electronic signals. Prior to running a test, the QwikCheck will automatically adjust the noise level thresholds to insure accurate readings.
- **Electronic spikes:** Checks for any measurement points that are out of range electronically. More than three such points will fault the system and a warning message will be displayed.

### Instructions for printing the QwikCheck GOLD Self Test parameters to prepare for technical support:

How to print a copy of the SELF TEST DATA:

- Remove the testing capillary from the system.
- When a FAILED SELF TEST message appears select: **MAIN MENU > SERVICE> PRINT SELF TEST DATA AND SETTINGS > SELF TEST DATA.**
- Press **ENTER** after highlighting **SELF TEST DATA** to print a copy of the data.

How to view the system parameters FROM QwikCheck GOLD:

- Go to: **MAIN MENU > SERVICE > SERVICE DATA.** All of the service screens can be viewed by pressing ENTER.

**Customer Support/Troubleshooting:** To quickly assess if the QwikCheck GOLD is in good calibration, refer to the table and values below. The S/W Ver. 1.00 column provides reference ranges for calibration. Enter information from the SELF TEST DATA in the "QwikCheck Value" column to see if the system requires troubleshooting.

#	Parameter	S/W Ver. 1.00	QwikCheck Value	Pass	Fail
1.	Ref 1	150 – 350 mV			
2.	LED Cur 1	5 – 25 mA			
3.	Amplitude	50 – 100 mV			
4.	Zero Level	500 - 525			
5.	Ref 2	2500 – 3500 mV			
6.	LED Cur 2	10 – 32 mA			
7.	CONC. 1	0 – 1 M/ml			
8.	CONC. 2	50-150 M/ml			
9.	CONC. 3	300-600 M/ml			
10.	Count (Service Data, Item #12)	26 - 36			

**Test Credit Loading**

**SECTION 6: Add I-Button Tests or Test Credit (TC) Codes**

\*\*\*For users implementing the new **TC-Code internal feature**, please reference the TC-Code Quick Start Guide found in the accessory kit or visit [www.testcreditcode.com](http://www.testcreditcode.com) for instruction on how to load Test Credits onto your device.

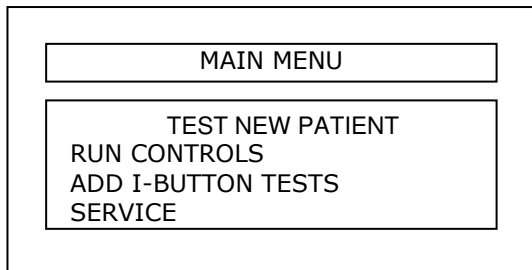

- To add I-button tests, go to: **MAIN MENU > ADD I-BUTTON TESTS** and press **ENTER**. The screen below will be displayed.

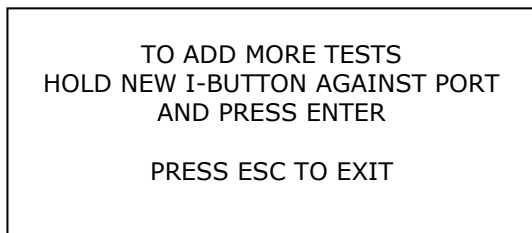

- Follow the on-screen instructions, holding the new i-button firmly against the i-button port located on the side of the QwikCheck GOLD system.

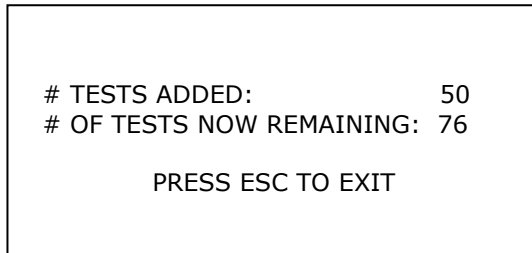

- The screen above will be displayed when the i-button is successfully loaded!



## SECTION 7: Service Menu

System set-up, maintenance and troubleshooting can be performed from the SERVICE MENU. To activate this screen, press **SERVICE** in the MAIN MENU.

SERVICE MENU

**SERVICE DATA**

SET-UP

SERVICE PERSONNEL

PRINT SELF-TEST DATA & SETTINGS

### Service Data

Click on this option to view all the SELF TEST, ALGORITHM and SERVICE DATA for the QwikCheck GOLD system.

Click on the SET-UP option to set-up all the **SYSTEM DEFAULTS** (date format; time/date; # labels to print; automatic printing; morphology setting) or to set-up the **CONTROL DEFAULTS**.

### Set-up

**SYSTEM DEFAULT SETTINGS**

DATE FORMAT: MM/DD/YY / DD/MM/YY

DATE/TIME SETTING: 01/04/05 08:15:45

MORPH SETTING: WHO 3RD (WHO 4TH)

AUTO PRINTING: YES/NO

# LABELS TO PRINT: 1 / 2

**SERVICE: SET-UP CONTROLS**

SELECT: LATEX BEADS / STABILIZED SPERM

SELECT: LEVEL 1/LEVEL 2/NEGATIVE

PRESS ENTER TO CONTINUE  
ESC TO RETURN TO SET-UP MENU

### Service Personnel

A **code** is required to access SERVICE PERSONNEL. This option allows a qualified service technician to access calibration and maintenance settings.

### Print system Default Settings

The system SELF-TEST DATA and DEFAULT SETTINGS can be printed to the label maker by selecting this option.

HIGHLIGHT OPTION  
AND PRESS ENTER TO PRINT

1. SELF-TEST DATA
2. CONTROLS / TEST SETTINGS

## SECTION 8: Error Messages and Warning Messages

### General Warning:

- The QwikCheck Gold equipment's built-in protection for the operator and the environment is ONLY operational if the QwikCheck Gold is operated properly following the manufacturer's specifications.
- **CAUTION:** There is a risk of explosion or shorting if the QwikCheck Gold battery is replaced by an incorrect type. Replacement batteries MUST be the same type and manufacturer. Dispose of used batteries in accordance with the manufacturer instructions.
- Following the manufacturer's recommended use, the expected life span of the QwikCheck Gold is a minimum of 5 years. The life span can be extended when utilizing the manufacturer's annual preventative maintenance plan.

### Stabilization Failed:

```
STABILIZATION FAILED
TURN OFF MAIN SWITCH ON REAR PANEL
REACTIVATE UNIT
IF PROBLEM PERSISTS,
CALL FOR TECHNICAL SUPPORT
```

- Ensure there is no testing capillary in the measurement compartment.
- Remove the SYSTEM from sources of electronic noise (cell phones, etc.) and vibrations (centrifuge).
- Clean measurement compartment (refer to Appendix).
- Reboot the QwikCheck system without a testing capillary in the chamber:
  - Turn system **OFF** then back **ON** at the main switch on the rear panel.
  - Press the front panel **ON/OFF** key to begin Auto-Calibration/Stabilization.
- Call technical support if failure recurs.

### Self-test Failed:

```
FAILED SELF-TEST
TURN OFF MAIN SWITCH ON REAR PANEL.
CLEAN OPTICAL CHAMBER.
REACTIVATE UNIT.
IF PROBLEM PERSISTS
CALL FOR TECHNICAL SUPPORT
```

- Ensure there is no testing capillary in the measurement compartment.
- Remove the QwikCheck from sources of electronic noise (cell phones, etc.) and vibrations (centrifuge).
- Clean measurement compartment (refer to Appendix).
- Reboot the QwikCheck system without a testing capillary in the chamber:
  - Turn the system **OFF** then back **ON** at the main switch on the rear panel.
  - Press the front panel **ON/OFF** key to begin Auto-Calibration/Stabilization.

- Call technical support if this message is displayed again. Prepare for technical support by printing a copy of the **SERVICE DATA**:
  - Press the SERVICE key on the keypad to activate the **SERVICE MENU** screen.
  - Select: **PRINT SELF TEST DATA AND DEFAULT SETTINGS>SELF TEST DATA.**
  - Press **ENTER**

#### Electronic Noise:

ELECTRONIC NOISE.  
TURN OFF MAIN SWITCH ON REAR PANEL.  
EACTIVATE UNIT.  
IF PROBLEM PERSISTS,  
CALL FOR TECHNICAL SUPPORT

- Ensure there is no testing capillary in the measurement compartment.
- Remove the QwikCheck from sources of electronic noise (cell phones, etc.) and vibrations (centrifuge).
- Clean measurement compartment (refer to Appendix) and after cleaning:
  - Turn the system **OFF** then back **ON** at the main switch on the rear panel.
  - Press the front panel **ON/OFF** key to begin Auto-Calibration/Stabilization.
- From **MAIN** menu: Select **TEST NEW PATIENT** and rerun the test.
- Call technical support if this message is displayed again. Prepare for technical support by printing a copy of the **SERVICE DATA**:
  - Press the SERVICE key on the keypad to activate the **SERVICE MENU** screen.
  - Select: **PRINT SELF TEST DATA AND DEFAULT SETTINGS>SELF TEST DATA** and then press **ENTER.**

#### Concentration Out of Range

##### Testing Semen Sample:

TEST RESULTS  
OUT OF PHYSIOLOGICAL  
RANGE  
RETEST SAMPLE?  
YES/NO

- A message will appear indicating that the tests results for Sperm Conc and/or MSC are beyond the upper limits of the dynamic range established by the manufacturer for testing. This message will appear when:
  - SPERM CONC > 500 M/ml or
  - MSC > 450 M/ml
- Review sample handling technique (see Appendix "Filling the SQA Capillary").
- Re-test the sample using a new SQA capillary. If the message appears again, reboot the system.
- Call for technical assistance if problem persists.

**APPENDIX 1: Filling the Testing Capillary with a Normal Volume Sample**

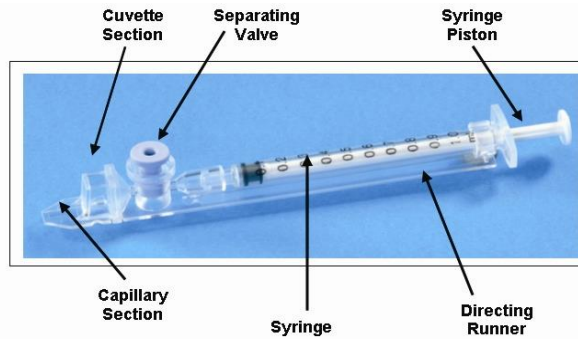

**Sample size, collection container and preparation:**

1. Sample volume should be **at least .5 ml**. If sample volume is less than .5 ml see Appendix 2.
2. The semen sample must be **completely liquefied and well mixed prior to aspiration**. **WARNING:** Do not shake nor use a pipette to aspirate and dispense specimen in order to mix, otherwise air bubbles will form.
3. **Carefully check that liquefied, fully mixed specimen is free of air bubbles** before aspirating a sample.



**Figure 1**

**Filling the capillary:**

1. **Push the syringe piston in fully**. Place only thin part of the capillary into the bottom of the sample while angling the sample container at about 45 degrees (Figure 1).
2. Place two fingers below the piston head and **pull the piston back slowly while keeping the tip of the capillary well below the sample level and below any surface bubbles** (Figure 1). Continue to aspirate the sample until it appears in the Luer adaptor (figure 2).
3. Hold the capillary in a vertical position to **confirm that the sample has completely filled** the thin section (without a meniscus) and the cuvette section (Figure 2).
4. **Tap on the syringe to make sure there are no air bubbles** in the sample. If, after tapping, some air bubbles appear below the Luer adaptor, dip the capillary into the semen sample again and aspirate a small quantity of semen to draw the air bubbles into the syringe.
5. Quickly (to avoid wicking) **wipe the outer surface of the capillary** - both top and bottom with a wipe to prevent the QwikCheck optical chamber from becoming clogged (Figure 3).
6. Slowly **push-in the separating valve** all the way-level with the plastic (Figure 4). Insert the capillary into the QwikCheck measurement compartment as far as it will go (Fig 5). Testing begins automatically.



**Figure 2**



**Figure 3**



**Figure 4**



**Figure 5: Insert capillary**

## APPENDIX 2: Filling the Testing Capillary with a Low Volume Sample

### Sample size, collection container and preparation:

1. Fill only the tip of the capillary (20 micro liters) to test only motility parameters (Figure 1).
2. The semen sample must be **completely liquefied and well mixed prior to aspiration**. **WARNING:** Do not shake nor use a pipette to aspirate and dispense specimen in order to mix, otherwise air bubbles will form.
3. **Carefully check that the liquefied, fully mixed specimen is free of air bubbles** (or that there is an adequate amount of sample below the air bubbles) before immersing the capillary into the specimen, thus ensuring that no air bubbles will be aspirated into the capillary.



Figure 2



Figure 1

### Filling the capillary:

1. **Push the syringe piston in fully**. Place only the thin part of the capillary into the bottom of the sample (Figure 1).
2. **Pull the piston back slowly** without withdrawing the capillary from the sample. **Fill only the (thin) capillary chamber** with 20 micro liters of semen (Figure 1).
3. The quantity aspirated can be determined by the gradations on the 1 ml syringe. Aspirate the sample until it just appears in the cuvette.
4. After filling, visually inspect the capillary to ensure that the sample has completely filled the thin section (no meniscus).
5. Quickly (to avoid wicking) **wipe the outer surface of the capillary tip** with a wipe to remove all semen in order to prevent the QwikCheck optical chamber from becoming clogged.
6. Visually confirm that the thin chamber of the capillary is still full of semen after completing the cleaning process. If some of the sample has been depleted push-in the piston slightly until the first drop appears on the capillary tip and then fill the capillary again from the sample container.



Figure 3

Figure 4



7. The separating valve must now be removed. Detach the entire syringe from the hub (Figure 2) and use the syringe tip to firmly **push-out the separating valve** from the underside of the capillary (Figure 3). Completely detach the separating valve (Figure 4). The capillary is now ready to be inserted into the QwikCheck measurement compartment.

**PLEASE NOTE: Test Low Volume samples as soon as the sample is aspirated into the capillary.**

### APPENDIX 3: Cleaning the Capillary Compartment

#### When to clean:

Daily or after every 10-15 tests

If the system fails **SELF-TEST**

#### Cleaning kit components:

Cleaning capillaries – one time use only (fig 1)

Sponge-tipped drying capillaries – one time use (fig 2)

Cleaning brush -wooden-handled (fig 4)

Cleaning fluid

**PLEASE NOTE: both the cleaning and drying capillaries are for ONE TIME USE ONLY – repeated use can damage the system!**

#### CLEANING: STEP 1

1. **TURN OFF** the QwikCheck
2. Use a **CLEANING** fibrous material capillary (fig 1)
  - Moisten with **ONE** drop of cleaning fluid, shaking off excess fluid.
  - Insert into the measurement compartment - fibrous material facing up. Move back and forth a few times. **Repeat with the material facing down.**
3. Use a sponge-tipped drying capillary to dry the same compartment. (fig 3)

#### CLEANING: STEP II

- Insert the brush (bristle-side down) into the lower chamber of the QwikCheck system (fig 5)
- Pull the brush out of the chamber while sweeping or "dusting off" the lens (you will feel a step or shelf at the back and top of the chamber – this is the top of the lens).
- Switch QwikCheck ON and observe self-test results. The QwikCheck should now PASS the self-test. If not, repeat cleaning procedure with the brush.

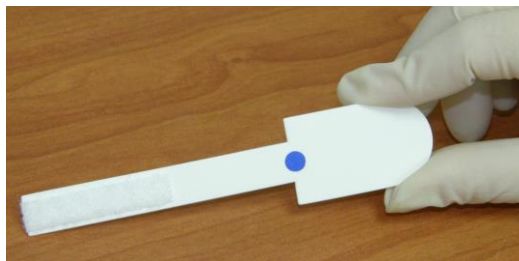

Figure 1

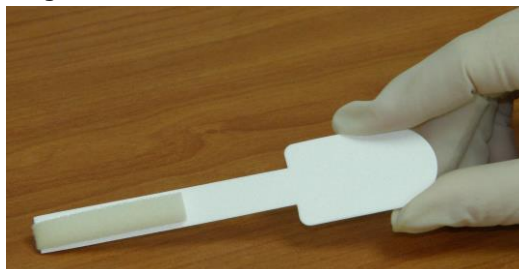

Figure 2



Figure 3



Figure 4



Figure 5

**APPENDIX 4: Reference Values of Semen Variables**

<b>SEMEN PARAMETER</b>	<b>QwikCheck TEST NAME</b>	<b>REFERENCE RANGE*</b>	<b>SOURCE</b>
Sperm Concentration (Count)	SPERM CONC.	≥20 M/ml	WHO 4th manual*
Motility (grades a+b+c)	MOTILITY <a+b+c>	-	-
Rapid Progressive Motility (grade a)	RAPID PROG. MOTILITY <a>	≥50% <a+b> or ≥25% <a> only	WHO 4TH manual*
Slow Progressive Motility (grade b)	SLOW PROG. MOTILITY <b>		
Non Progressive Motility (grade c)	NONPROG. MOTILITY <c>	-	-
Immotility (grade d)	IMMOTILITY <d>	-	-
Functional Sperm Concentration	FSC	≥ 7M/ml (WHO 3 <sup>rd</sup> ) ≥3M/ml (WHO 4 <sup>th</sup> )	
Morphology (% Normal Forms:WHO 3 <sup>rd</sup> )	MORPH. NORM FORMS WHO 3rd	≥30%	WHO 3rd manual*
Morphology (% Normal Forms:WHO 4 <sup>th</sup> )	MORPH. NORM WHO 4 <sup>th</sup> Strict	≥15%? (Under investigation)	WHO 4 <sup>th</sup> manual*
Motile Sperm Concentration	MSC	-	-
Progressively Motile Sperm Concentration (grade a)	PMSC <a>	≥10 M/ml <a+b> or ≥ 5 M/ml <a> only	MES Ltd.*
Progressively Motile Sperm Concentration (grade b)	PMSC <b>		
Velocity (Average path velocity – VAP)	VELOCITY	≥5 mic./sec.	MES Ltd.*
Total Sperm Number	SPERM #	≥40 M/ml	WHO 4TH manual*
Total Motile Sperm	MOT. SPERM	-	-
Total Progressively Motile Sperm	PROG. SPERM	≥20 M	MES Ltd.*
Total Functional Sperm	FUNC. SPERM	≥ 14M/ml (WHO 3 <sup>rd</sup> ) ≥ 6M/ml (WHO 4 <sup>th</sup> )	

\*Each laboratory should establish its own reference ranges for semen parameters. The ranges established above are based on WHO 3<sup>rd</sup> or 4<sup>th</sup> standards or MES Ltd. (for proprietary semen parameters)

## APPENDIX 5: Product Performance Data

### Abbreviations

TSC:	Sperm Concentration (Count)	MSC:	Motile Sperm Concentration
PMSC:	Progressive Motile Sperm Concentration	Morph Norm Forms:	Morphologically Normal Forms
OD:	Optical Density	MV:	Millivolt

### Performance Data Summary

The performance the QwikCheck™ GOLD Sperm Quality Analyzer is the same as the SQA-V (Sperm Quality Analyzer – VISUAL) as they share the same algorithms. Comparison data is available upon request. The following text, tables and graphs demonstrate the performance of the SQA-V algorithms. All values concerning sperm concentration measurements are expressed as 10<sup>6</sup> sperm cells per milliliter (M/ml). Motility and morphology values are expressed as a percent (%). Unless otherwise noted all testing was performed using human donor semen samples.

### Calibration:

Each SQA is biologically calibrated against two reference systems at Medical Electronic System's laboratory.

### Dynamic Range:

Sample Type	Test Mode	Sperm Conc. M/ml	Motility %	Morph %	MSC M/ml	PMSC M/ml	#Sperm Cells/field
Fresh	Normal	2-400	0-100	0-100	.2-400	0-400	-
Washed	Normal	2-200+	0-100	0-100	.2-200+	0-200+	-
Frozen	Normal	-	-	-	.2-200+	0-200+	-

### Precision and Accuracy Established Against a Known Target (Latex beads)

**Background:** The precision and accuracy of the SQA was compared to a known target value using latex beads.

Latex beads are used as a quality control product to validate the accuracy of sperm counting methods for two known levels of concentration. In accordance with CLIA regulations such a control is used to demonstrate operator proficiency using the microscope and for validation of automated sperm counting methods. The latex beads were run in the SQA in the same manner semen samples are run on the system.

#### Limitations of method:

Latex beads cannot:

- Measure sperm motility or morphology
- Correct for inaccurate chamber depths or technician errors

#### Method comparison:

A total of 320 latex bead samples were tested on ten SQA systems (32 samples/SQA). SQA concentration readings were compared to established target values +/- acceptable range.

#### Latex beads established target values +/- ranges (Hemocytometer):

- Vial #1: 47 +/- 7.0 M/ml
- Vial #2: 24 +/- 3.4 M/ml

### Precision

SYSTEM	Latex-beads	CV, %
Intra-device Variability	<b>High 47± 7.0 M/ml</b>	≤ 0.01
	Low 24 ± 3.4 M/ml	≤ 0.01
Inter-device Variability	<b>High 47± 7.0 M/ml</b>	≤ 2.00
	Low 24 ± 3.4 M/ml	≤ 2.50

### Accuracy: High Level Control

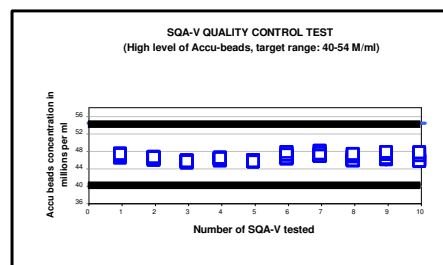

### Accuracy: Low Level Control

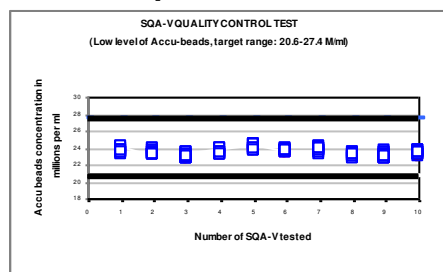



**Precision and accuracy established in clinical trials using human semen samples**

**Clinical claims:**

*Specificity*

- Concentration: 85%
- Motility: 80%
- Morph. Norm Forms (WHO 3<sup>rd</sup>): 65%
- Morph. Norm Forms (WHO 4<sup>th</sup>): 60%
- Postvasectomy: 95% of motile cells detected

*Sensitivity*

- Concentration: 90%
- Motility: 85%
- Morph. Norm Forms (WHO 3<sup>rd</sup>): 85%
- Morph. Norm Forms (WHO 4<sup>th</sup>): 65%

*Correlation to Manual Method*

- Concentration: 0.9
- Motility: 0.85
- Morph. Norm Forms (WHO 3<sup>rd</sup>): 0.65
- Morph. Norm Forms (WHO 4<sup>th</sup> strict): 0.45

*Linearity*

Linear Sperm Concentration throughout the SQA dynamic range of 2M/ml to 400M/ml

- Squared regression coefficient of Dilution Curve  $R^2 \geq 0.9$ .
- Averaged coefficient of variation CV of measured vs. expected sperm concentration  $\leq 20\%$ .

*Note: Claims are less than actual correlations noted (see tables 1 and 2)*

**Background:** The SQA concentration, motility and morphology readings were compared to standard microscopic readings using a Makler or Neubauer chamber based on WHO 4TH standards and MES protocols. Three independent clinical trials were conducted at three sites. A total of 539 human semen samples were analyzed as described below: 342 samples were of low quality and were tested in the High Sensitivity mode.

#Samples	Fresh	Washed	Frozen	High Sensitivity
539	125	42	30	342

**Precision (Table #3):** Duplicate samples were assessed using 2 SQA's. The coefficients of variation (CV) characterizing precision were calculated for Sperm Concentration and Motility and were below 6%.

**Specificity:**

- To achieve analytical specificity a specific wave length of light which is maximally absorbed by sperm cells and minimally absorbed by other cells and seminal plasma is used.
- Low noise and high electronic resolution hardware components and compensation circuits ensure that analytical specificity is optimized.

**Limitations of clinical specificity:**

- Highly viscous samples cannot be read accurately unless treated with QwikCheck Liquefaction.
- % Normal Morphology is a parameter derived from the correlation between morphology and progressive motility. This is not a direct measurement.
- Dynamic range limitation as stated above.

**Table 1: Sensitivity/Specificity**

SQA vs. Microscope	Sensitivity	Specificity
<b>Trial #1:</b>		
Concentration	100%	95%
Motility	97%	85%
Morph Norm Forms (WHO 3 <sup>rd</sup> )	94%	75%
<b>Trial #2:</b>		
Concentration	94%	90%
Motility	87%	90%
Morph Norm Forms (WHO 4 <sup>th</sup> )	69%	70%
<b>Trial #3: High Sensitivity* (see table#4)</b>		
Motile Sperm Cells	95%	95%
Immotile Sperm Cells	99%	100%

**Table #2: Correlation to Manual Method**

Parameters	Correlation Coefficients	
	Trial #1	Trial #2
Sperm Concentration M/ml	0.93	0.94
Motility %	0.86	0.87
Morphology WHO 3 <sup>rd</sup>	0.66	NA
Morphology WHO 4 <sup>th</sup>	NA	0.49
MSC	NA	0.79

**1st clinical trial - TSC correlation**

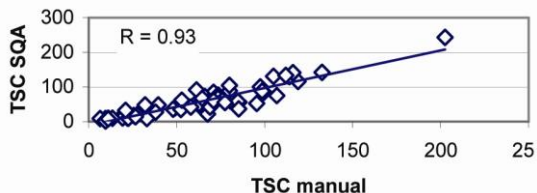

**2nd clinical trial- TSC correlation**

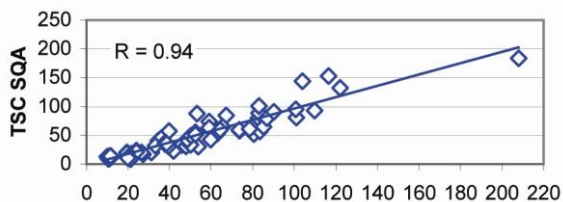

**Limitations of method:**

Samples were assessed by different operators using a microscope and the SQA. Inter-operator subjectivity may have affected the results of the study.

**Method comparison:**

- SQA was compared to the microscope based on WHO 4TH guidelines.
- Sensitivity and specificity were calculated using ROC curves. WHO 4TH guidelines were used to establish cutoffs for reference values (see table #1).
- 218 of the 342 semen specimens contained motile cells and were used as the basis for the method comparison (Table #4).

**SQA Linearity**

**Clinical claims:**

- Linear Sperm Concentration throughout the SQA dynamic range of 2M/ml to 400M/ml:
  - Squared regression coefficient of Dilution Curve  $R^2 \geq 0.9$ .

**Table #3: Precision**

Parameter	Range	Method	
		SQA CV%	Microscope CV%
Sperm Concentration M/ml	Entire Range	3.1	6.1
	5-40	5.2	5.9
	41-80	2.1	5.5
	>80	2.5	3.2
Motility %	Entire Range	5.1	7.2
	10-50	7.6	10.3
	51-55	1.5	3.4
	>55	6.0	4.1

**Table #4: Percentage Motile Cells Detected**

Method Comparison of 218 Samples with Motile Cells	# Samples Motile Sperm Detected	% Samples Motile Sperm Detected
SQA Automated System and Visualization System	207	95%
Visualization System only	193	89%
Microscope only	161	74%

- Averaged coefficient of variation CV of measured vs. expected sperm concentration  $\leq 20\%$ .

**Goal:** To demonstrate the ability of the SQA to accurately report sperm concentration along the dynamic range of the system using sequentially diluted human semen samples.

**Methodology:** 4 fresh human semen samples were pooled, divided into two aliquots and centrifuged at 600g for 15 minutes. The seminal plasma was decanted and the pellets were re-suspended in washing media: DPBS & HEPESHTF. Sequential dilutions were run in 4 SQA systems.

**Limitations of method:**

- Dilution errors contribute to the accuracy of the linearity test results.
- Sample handling errors such as the introduction of bubbles into the testing capillary can cause inaccurate readings.

**1st clinical trial- Motility correlation**

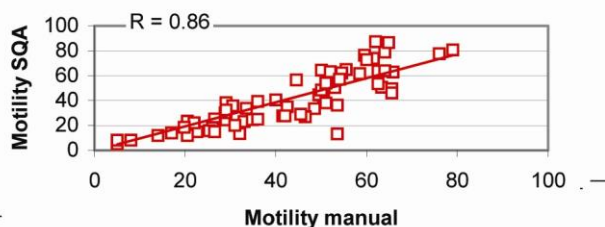

**2nd clinical trial - Motility correlation**

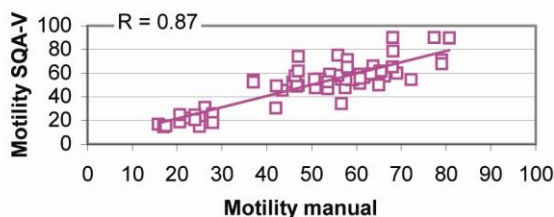

**2nd clinical trial - MSC correlation**

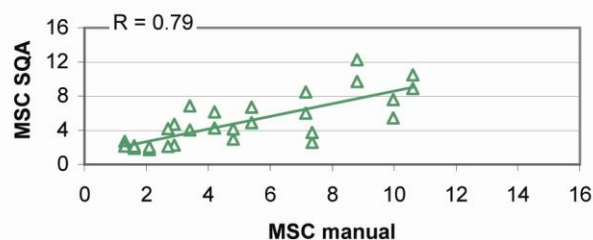

**SQA-V DILUTION CURVE USING SEMEN DILUTED WITH DPBS & HEPES SOLUTION**

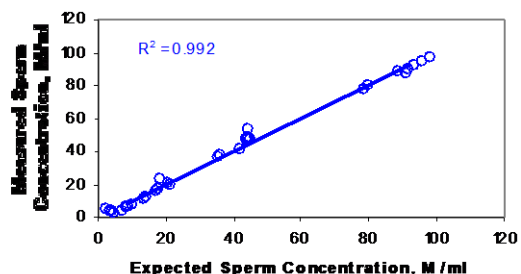

**Results:**

1. Squared regression coefficient  $R^2$  of Dilution Curve (trend line) was found to be 0.992 (note graph displaying results of four SQA's and DPBS and HEPES dilution media).
2. Averaged coefficient of variation CV of measured vs. expected sperm concentration was 10%.

**APPENDIX 6: Service Report**

**SQA SERVICE SUPPORT  
Parameter Report**

Device number: \_\_\_\_\_ Software Version: \_\_\_\_\_ Date: \_\_\_\_\_

Instruct the user to run a SERVICE report. For the QwikCheck GOLD system go to: **MAIN MENU > PRINT SELF TEST DATA AND DEFAULT SETTINGS>SELF TEST DATA.**

**Calibration parameters:**

Fill-in the USER REPORT column with the calibration parameters found in the INTERNAL DATA SECTION of the SERVICE DATA REPORT of the QwikCheck GOLD. Contact your local distributor for the initial calibration parameters. These parameters should not have changed.

Parameter	Service Report Item #	User Report	Initial Calibration settings	Comments
CONTR.REF1	#1			
OD AMPLIF.	#13			
MSC AMPLIF	#8			
OD VALUE	#15			
OD CORR	#16			
LB OD AMP	#18			
CONTR. Z.L*	#11			

\*CONTR. Z.L. can be adjusted in the field by a MES trained service technician

**Algorithm parameters**

Fill-in the User Report values for the following algorithm parameters found in the SERVICE DATA REPORT. The QwikCheck algorithm settings are defined and should not have changed.

Parameter	Service Report Item #	User Report	Initial Settings	Comments
MIN.SP.HEIGHT	#2			
MIN.SP.WIDTH	#9			
MAX.SP.WIDTH	#3			
NOISE THRESH	#10			
SMI THRESH	#4			

**Self Test Parameters:**

Fill-in the QwikCheck SELF TEST PARAMETERS from the SELF TEST printout in V-Sperm:

- From the **MAIN MENU** go to: **SERVICE>PRINT SELF TEST DATA AND DEFAULT SETTINGS>SELF TEST DATA.**
  - Verify that the parameters listed below fall within the established range
  - Highlight the discrepancies and report to MES

<i>Parameter</i>	<b>S/W Ver. 1.00 Criteria</b>	<b>SYSTEM Self-Test Parameters</b>	
Ref. 1	150 – 350 mV		
<b>LED Current 1</b>	<b>5 – 25 mA</b>		Original value
Amplitude	50 – 100 mV		
Count (#12)	26 – 36		
Zero Level	500 – 525		
Ref. 2	2500 – 3500		
<b>LED Current 2</b>	<b>10 – 32 mA</b>		Original value
TSC 1 or CONC 1	0 – 1 M/ml		
TSC 2 or CONC 2	50 – 150 M/ml		
TSC 3 or CONC 3	300 – 600 M/ml		

**APPENDIX 7: QwikCheck™ Reports**

**Semen Analysis Report**

QwikCheck™ GOLD  
**SEMEN ANALYSIS REPORT**  
 DEVICE SN# 382  
 SW VER. 01.XX.XX  
 TEST DATE 3/12/04 15:26  
 PATIENT ID 232345333  
 BIRTH DATE 11/22/51  
 ABSTINENCE 3 DAYS  
 ACCESSION #: 464444  
 COLLECTED 11/22/04 12:20  
 RECEIVED 11/22/04 12:25  
 TYPE FRESH/WASHED  
 VOLUME 3.5ml  
 WBC CONC. <= 1M/ml  
 PH 7.5

**TEST RESULTS**  
 CONC. 32.6M/ml  
 MOTILITY 27.9%  
 RAPID <a> 6.1%  
 SLOW <b> 10.0%  
 NONPROG. <c> 11.8%  
 IMMOT. <d> 72.1%  
 N.MORPH 10.1%  
 MSC 9.1M/ml  
 PMSC <a> 1.0M/ml  
 PMSC <b> 5.7M/ml  
 FSC 4.2M/ml  
 VELOCITY 29 mic/sec  
 SMI 341

**TOTALS PER EJACULATE**  
 # SPERM 114.1M  
 MOT. SPERM 31.9 M  
 PROG. SPERM 22.4 M  
 FUNC. SPERM 14.7 M

**SYSTEM Default Settings  
 CONTROLS**

QwikCheck™ GOLD  
**SETTINGS**  
 DEVICE SN# 382  
 SW VER. 01.XX.XX  
 PRINT DATE 14/01/04 15:33  
 DATE FORMAT DD/MM/YY  
 TIME FORMAT HH:MM  
 MORPH. WHO 3rd (or 4<sup>th</sup>)

**CONTROLS**  
 LATEX BEADS (or STABIL.  
 SPERM)  
 LEVEL 1  
 LOT # 5435334656565656  
 EXP. DATE 05/05  
 TARGET VALUE 45M/ml  
 RANGE +/- 5.0M/ml

LEVEL 2  
 LOT # 75664767676776  
 EXP. DATE 05/05  
 TARGET VALUE: 23M/ml  
 RANGE +/- 2.1M/ml

LEVEL NEGATIVE  
 LOT # 5464565465656566  
 EXP. DATE 05/05  
 TARGET VALUE: 0.0M/ml

**Service Data Report**

QwikCheck GOLD  
**Service Report**  
 DEVICE SN# 382  
 SW VER. XX.XX.XX  
 PRINT DATE 01/12/08

**SELF-TEST DATA**  
 REF1 230 REF2 2925  
 LED1 9 LED2 24  
 AMP 65 CONC1 0.0  
 SMI 409 CONC2 104.6  
 ZL 508 CONC3 418.9  
 AW 14987

**SERVICE DATA**

1.	16	7.	0.000	13.	100
2.	5	8.	115	14.	100
3.	150	9.	10	15.	1.70
4.	28	10.	6	16.	100
5.	0.95	11.	130	17.	3
6.	512	12.	31	18.	1000

**APPENDIX 8: Warranty**



**Sperm Quality Analyzer**

**SQA, QwikCheck™ GOLD**

**Warranty**

Medical Electronic Systems ("MES") warrants that the Sperm Quality Analyzer will be free from defects in workmanship and materials for a period of twelve (12) months from date of purchase. During the warranty period, if the device is shown to MES's reasonable satisfaction to be defective, MES shall, at its option, repair such a device without charge for parts or labor. The foregoing remedy shall be purchaser's sole and exclusive remedy under this warranty. In the event (i) purchaser makes any modifications or alterations to the SQA /QwikCheck GOLD or (ii) the SQA/QwikCheck GOLD is used, operated, opened or serviced other than as directed by MES or is damaged as a result of use, careless transportation (not in its original box, or within the allowed temperature range, operation or servicing other than as directed by MES, the foregoing warranties shall be void and of no further force or effect. EXCEPT FOR THE FOREGOING WARRANTIES, THE PRODUCTS ARE SOLD AS-IS AND WITHOUT ANY OTHER WARRANTY OF ANY NATURE WHATSOEVER. MES HAS NOT MADE AND DOES NOT MAKE ANY OTHER REPRESENTATION, WARRANTY, GUARANTY, OR COVENANT, EXPRESS OR IMPLIED, WITH RESPECT TO THE DESIGN, CONDITION, DURABILITY, SUITABILITY, FITNESS FOR USE, FITNESS FOR A PARTICULAR PURPOSE, OR MERCHANTABILITY OF THE SQA IN ANY RESPECT. UNDER NO CIRCUMSTANCES AND IN NO EVENT, WHETHER AS A RESULT OF BREACH OF CONTRACT OR WARRANTY, TORT (INCLUDING NEGLIGENCE AND STRICT LIABILITY) OR OTHERWISE, INCLUDING BUT NOT LIMITED TO INACCURATE RESULTS OR OPERATOR ERROR, SHALL MES BE LIABLE FOR ANY SPECIAL, INCIDENTAL OR CONSEQUENTIAL DAMAGES. IN NO EVENT SHALL MES'S LIABILITY WITH RESPECT TO THE PRODUCT EXCEED THE PURCHASE PRICE FOR SUCH PRODUCT.

**Extended service contracts are available for purchase.  
Please contact the dealer or supplier for information.**

Serial Number: \_\_\_\_\_ Date Purchased: \_\_\_\_\_  
Dealer: \_\_\_\_\_ Dealer Phone#: \_\_\_\_\_  
Purchaser: \_\_\_\_\_ Purchaser Phone #: \_\_\_\_\_

## **Appendix 9- Regulatory Information**

### **European Authorized Representative:**

Arazy group GMBH.  
The Squalre 12, Am Flughafen, 60549 Frankfurt am Main, Germany  
Email: [germany@arazygroup.com](mailto:germany@arazygroup.com) Tel: +49 69959325090

### **Australian Sponsor:**

Acrapack Pty Ltd, Anne Jones  
7/ 84 Poinciana Avenue, Tewantin QLD Australia 4565  
Email: [anne@acrapack.onmicrosoft.com](mailto:anne@acrapack.onmicrosoft.com)

### **Japanese MAH:**

Jaffco LTD, Hirofumi Morita  
Email: [hiro0205@xd5.so-net.ne.jp](mailto:hiro0205@xd5.so-net.ne.jp)  
17-15 Komazawa 1-chome Setagaya-ku  
Tokyo 1540012  
JAPAN

### **Manufacturer:**

Medical Electronic Systems, Ltd. 20 Alon Hatavor St., Zone 6, P.O.  
Box 3017, Caesarea Ind. Park 3088900, Israel

**Catalog # F-A-00464-00**